

Installation Instructions 8-5135 Gear Drive

BEFORE YOU BEGIN: READ ALL OF THESE INSTRUCTIONS FIRST !!!

Note: The installation procedures which follow assume that the engine has been disassembled and cleaned as it would be for a normal timing set change.

The following are some important notes concerning the installation of this gear drive.

1. The reverse idler gear (20 tooth idler) should have between .005 and .070 in vertical travel when the set is installed on the engine with the power idler (22 tooth idler) in hard mesh between the crank and cam gears. If this is not the case excessive heat can be generated causing damage to the gear set.
2. The purpose of the reverse idler gear is to prevent the power idler from disengaging when the crankshaft rotates backwards as happens in shutting off the engine.
3. The engine is timed with the timing marks facing one another just as you would with a chain and sprocket drive. (Refer to Figure 1)
4. Idler pins will always be in contact with the timing cover during use. **Back of idler pins must have a minimum of .015 clearance to block.**
5. On small block engines the rib on the inside of the timing cover must be removed.
6. The Dual Idler Gear Drive is intended for use with a harmonic balancer. **It is not for use with an aluminum hub.**

Installation instructions

1. With a dab of grease install bronze wear ring, included in kit on the back of cam gear.
2. Install cam gear on engine and install fuel pump eccentric and bolt. We recommend a one piece eccentric but a two piece eccentric if a spacer is placed behind the eccentric so that the outer ring can spin freely. Torque camshaft bolt to factory specification. Late model small blocks use a .251" thrust plate. Early models use a .217" thrust plate. 351C engines use a .156" thrust plate.
3. Install crank gear on engine. You can advance or retard the camshaft timing ± 2 cam degrees from factory setting by using the advanced keyway (triangle keyway and timing mark) or the retarded keyway (rectangle keyway and timing mark)
4. With the #1 piston at TDC line up timing marks on engine centerline (See Figure 1) slide idler gears in place with large gear on the passenger side of engine. On 351W and late model 302 engines the long pin in the idler assembly must be changed with the shorter pin supplied in the set. On some 351M and 400M blocks most of long pin must be ground off to allow proper clearance under the timing cover.
5. With the idler gears halfway on, push timing cover with gasket into place. Remove the cover. The gears should be aligned at least 90 % with the cam and crank gear. Use a feeler gage to check clearance between the block and the back of the idler pins. A minimum of .015" to .060" is required. If there is not sufficient clearance, remove the idler assembly and grind of material from the end of the idler pin closest to the block. Repeat step 3 until correct clearance is achieved.
6. With the idler assembly now in place, turn the crankshaft clockwise so that the power idler (large gear) is in hard mesh with cam and crank gear. There must be .005"-.070" vertical travel of the reverse idler (small gear.) Replace the idler bracket, and then install the timing cover.

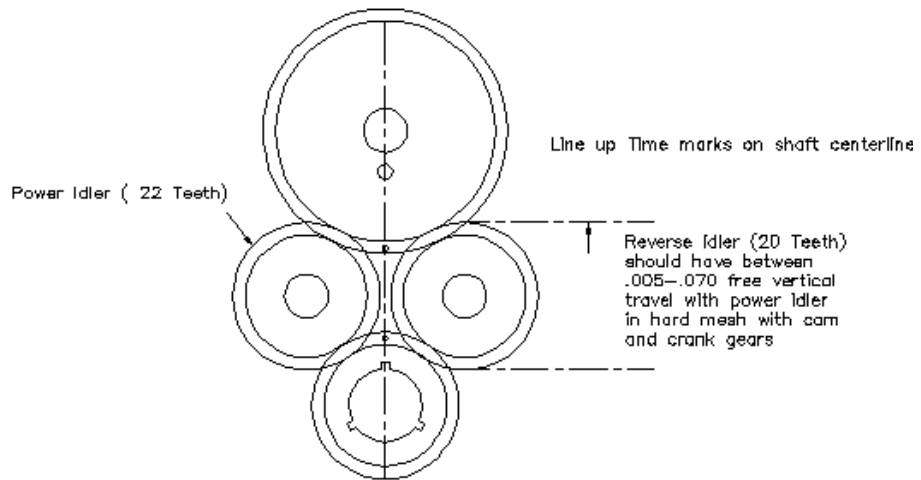

Figure 1

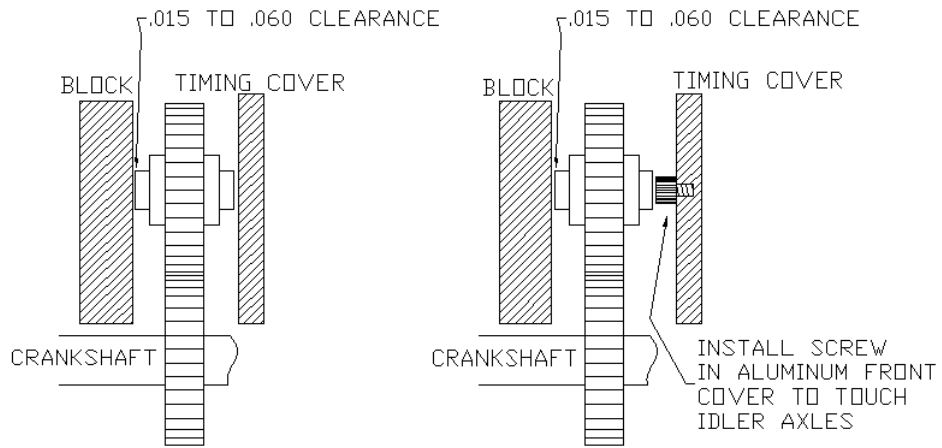

Figure 2